

Model 510.xxx and 510.xxxS Single-Station Battery Operated Controller

Installation, Programming and Operating Instructions

Features

- Weekly or cyclical program
- Four start times per day in weekly mode
- Irrigation duration – from 1 minute to 12 hours in 1 minute increments
- Water budget from -95% to +95% in 5% increments
- Semi-automatic or manual operation
- Rain delay up to 30 days
- Simple, four button rubber keypad programming
- Withstands harsh climatic conditions
 - ° Completely waterproof
- Can be mounted on a valve or on valve box wall
- Available with 3/4-20 threaded solenoid, 3/4", 1-1/2", 2" valves and 3/4" and 1" actuators to convert most manual antisiphon valves
- Available with rain sensor connection - Model 510.XXXS
- Operates using 2, 9-volt alkaline batteries
- 2 year maximum battery life



510.075-100



510.011



510.150-200



510.000

TABLE OF CONTENTS

Introduction	3
1. Controller parts identification	3
2. Battery installation	3
3. Valves or wall mounting	3
4. Installation of Model 510.000 - 510.000S	4
5. Installation of Model 510.075, 100, 150 and 200	5
6. Manual-mechanical operation	6
7. Parts identification 510.075, 100, 150 and 200	7
8. Assembly of Model 510.011	8
9. Installation of Model 510.011	9
10. Connecting 510.XXXS to rain sensor	9
11. Programming	10
12. Setting current time and day of the week	11
13. Time format (switching between AM/PM and 24 hour)	11
14. Setting the watering time (duration)	11
15. Selecting watering frequency	12
16. Setting a start time	13
17. Setting a start time for a cyclical or one-time watering (with option to delay valve start time)	13
18. Manual operation via the controller (semi-automatic)	14
19. "Rain off" (shutdown)	15
20. Budget	15
21. Sensor operation (510.xxxS only)	16
22. Missing program data	16
23. Flashing low battery warning	16
24. Constant low battery warning	16
25. Maintenance, troubleshooting and repairs	17
26. Warranty	18

INTRODUCTION

Thank you for purchasing the 510.xxx(S) single-station battery operated controller. Please take the time to read through the enclosed instructions and follow them step by step. If you have any questions, please call our Technical Service Line 1-800-322-9146.

1. CONTROLLER PARTS IDENTIFICATION

1. Top Cover
2. Controller Display
3. Bottom Cover
4. Battery Compartment Cover

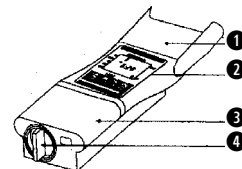

2. BATTERY INSTALLATION

Rotate the battery compartment cover handle counter clockwise to the "11 o'clock" position to remove the cover (see drawing). Install two 9-volt alkaline batteries onto the terminal clip. Insert into battery compartment and reinstall the cover. The controller display appears briefly followed by a water droplet on the lower left side of the display. The droplet will flash momentarily and shut off. When the display flashes "12:00", the controller is ready to be programmed.

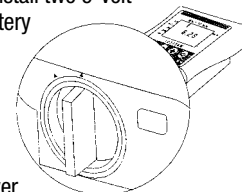

IMPORTANT: To replace the battery compartment cover, insert with the handle in the "11 o'clock" position and then rotate the cover 1/4" clockwise to avoid possible cover guide pin breakage.

3. VALVES OR WALL MOUNTING

3.1. VALVE MOUNTING

If the mounting plate [2] is attached to the controller, remove it.

1. Insert the mounting coupling [1] into the mounting plate, aligning the words "top", which are stamped on both the coupling, and the plate.

- Press the mounting plate, with the mounting coupling inserted, against the back of the irrigation controller.

3.2. WALL MOUNTING

The controller mounting plate [2] can be mounted on a wall using two screws (not included). In this situation the mounting coupling [1] is not used. Please be aware that the length of the controller connecting cable limits the distance between the controller and the solenoid.

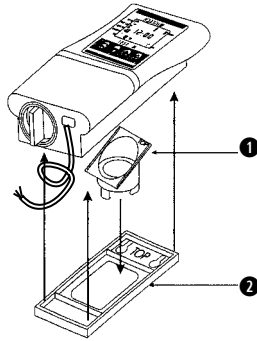

4. INSTALLATION OF MODEL 510.000

510.000 controller converts most two-way AC solenoid valves with 3/4"-20 thread. Use adapter model P00-997 to adapt into RAIN BIRD valve series GB, EF, DV, PE, PGA and EFB.

- Shut off the mainline to the valve.
- Remove the AC solenoid and plunger from the valve.
- Remove the "O" rings from the valve solenoid thread (if used).
 - WEATHERMATIC valves:** remove "O" ring (part #14) from the solenoid cavity and place around the male thread of the DIG DC solenoid.
 - RAIN BIRD valves:** remove the solenoid and use the adapter model P00-997 to convert RAIN BIRD solenoid thread to 3/4"-20.
 - IRRITROL valves:** lift and remove the manual bleed handle and "O" ring (if present). For 3/4" and 1" models with flow-control, use extension model P00-999.
 - SUPERIOR valves:** remove the SUPERIOR solenoid and "O" ring. Place one 1/2" ID x 11/16 OD "O" ring inside the solenoid cavity (not included).
 - BUCKNER valves:** remove the solenoid and "O" ring. Place the BUCKNER "O" ring around the bayonet thread. Make sure that the manual bleed lever on the valve (if available) is closed. Do not move the manual bleed

lever after installing the DIG solenoid assembly, it can damage the bayonet and the valve will stay open.

- Place "O" ring #2 in the center of the threaded bayonet adapter (see Figure 1).
- Thread the DIG bayonet assembly and hand tighten into the valve solenoid port.
- After installing the bayonet assembly into the valve, remove the solenoid from the bayonet adapter and make sure that "O" ring #1 is properly in place, then reattach the solenoid with a 90° clockwise turn.
- Turn the water supply on and pressurize the system. Make sure that the valve is operating correctly (the valve will open momentarily and shut off)
- Use the manual lever on the solenoid to test the valve by turning it to the left to open and to the right to close (see Figure 3). If the valve opens and closes, turn the lever to the automatic position (center).
- Program the controller (see #11 Programming).

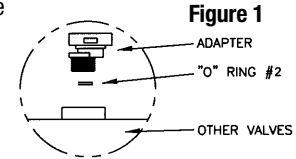

5. INSTALLATION OF MODEL 510.075, 100, 150 AND 200

The 510.xxx controller can be installed in-line and below grade (see Figure 2).

NOTE : Make sure the flow direction arrow is pointed away from the water source. Never use the controller unit as a handle for tightening the valve to the pipe.

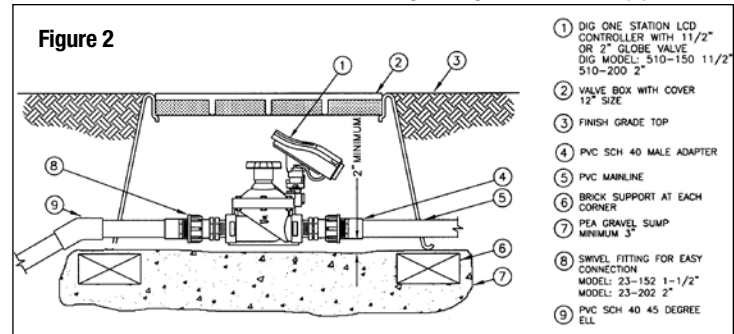

1. Shut off the mainline to the valve.
2. Before installing the controller to the irrigation system, flush the mainline. Then remove the solenoid (see Figure 4) from the valve with a 90° counter-clockwise turn. Be careful not to lose the seal (O-Ring #1).
3. Install the valve paying attention to the correct water flow direction as indicated by the arrow on the valve.
4. After installing the valve, reattach the solenoid with a 90° clockwise turn. Be sure to place the seal (O-Ring #1) in its proper location.
5. Turn the water supply on and pressurize the system, making sure that the valve is operating correctly (the valve will open momentarily then shut off).
6. Use the manual lever on the solenoid to test the valve by turning it to the left to open and to the right to close. If the valve opens and closes, return the lever to the automatic position (center).
7. Program the controller (see programming #11).

NOTE : If controller installation is used with swivel manifold fittings make sure to hand tighten the swivel cap to the PVC male adapter. If using PVC fittings wrap all fittings with teflon tape. **Do not use thread paste on the valve as this will cause damage and void the warranty.**

6. MANUAL-MECHANICAL OPERATION

The valve can be manually opened and closed independent of the controller operation. Manual operation is useful when immediate irrigation is required, without the delay of controller programming.

The 3-position manual lever (see Figure 3) is located on the solenoid the manual lever, and functions as follows: Open [1], Automatic Operation [A], Closed [2].

NOTE : For automatic operation, the valve handle must be in the middle [AUTO] position.

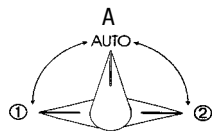
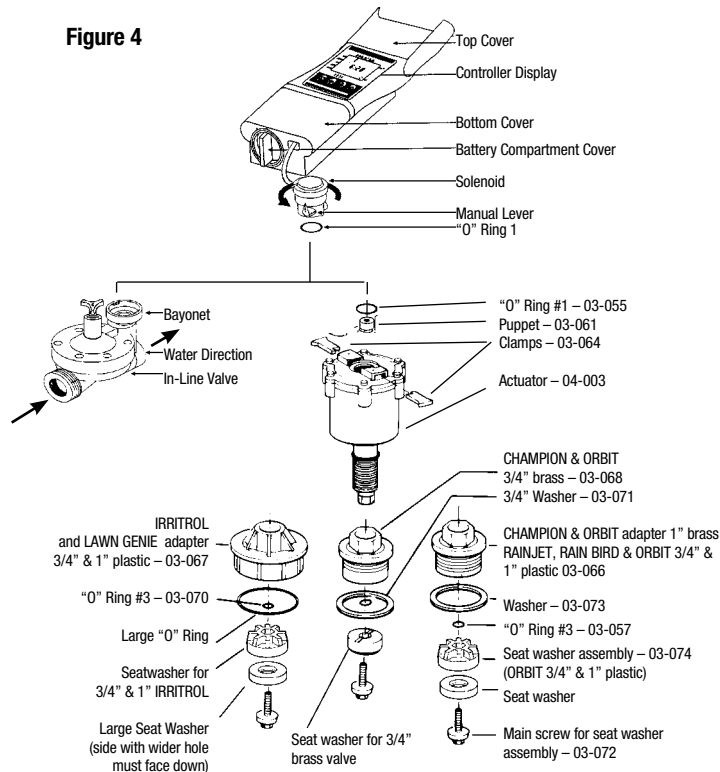

Figure 3

7. PARTS IDENTIFICATION 510.075-100-150-200

Figure 4



8. ASSEMBLY OF MODEL 510.011

The DIG valve actuator comes factory assembled to fit 3/4" CHAMPION and ORBIT manual anti-siphon brass valves. Included in the package are adapters to fit 1" CHAMPION, ORBIT manual anti-siphon brass valves, and 3/4" and 1" RAIN BIRD, RAINJET, LAWN GENIE, ORBIT and IRRITROL manual anti-siphon plastic valves.

NOTE: Please select the proper adapter.

8.1 ASSEMBLE PROPER ADAPTER (IF REQUIRED) (Figure 6)

1. Remove the main screw with a pair of pliers by turning the screw counter clockwise.
2. Remove the 3/4" seat washer, then the 3/4" adapter by turning the adapter counter clockwise.
3. Replace the actuator with the proper adapter and seat washer. Make sure that the seal ("O" ring #3) is in place.
4. Replace the main screw and tighten firmly, do not over tighten.

NOTE: Make sure that O-Ring #3 is in place.

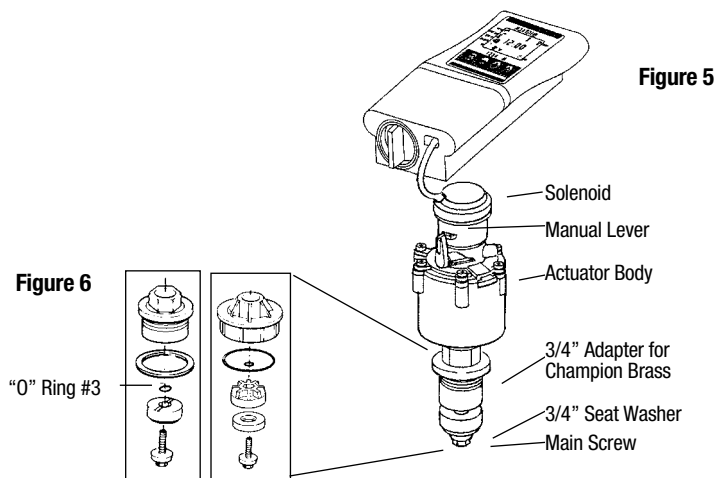

9. INSTALLATION OF MODEL 510.011

1. Shut off the mainline to the valve.
2. Remove the manual stem from the existing valve. If converting an anti-siphon valve, temporarily remove the anti-siphon cap (see Figure 7a).
3. Replace any existing worn washers with the new ones provided.
4. Install the actuator onto the valve (see Figure 7b) using a wrench, tighten firmly, but do not over tighten.
5. Rotate the actuator clockwise until completely closed (see Figure 7c).
6. Turn the water supply on and pressurize the system, making sure that the anti-siphon valve is operating correctly (the anti-siphon valve will open momentarily and then shut off).
7. Turn the solenoid manual lever to the left for manual On. Slowly rotate the actuator counter clockwise until the desired pattern is achieved.
8. Turn the manual lever to the center Auto Sprinkler upright position. If the valve does not shut off completely, slowly rotate the actuator clockwise until the valve shuts off.
9. Program the controller (see #11 Programming).

NOTE: For manual Off turn the lever to the right and for automatic operation to the center.

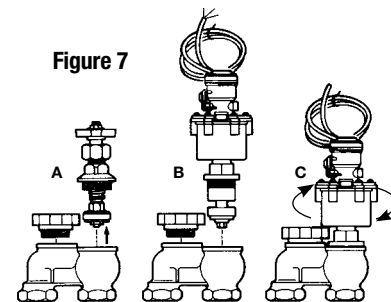

10. CONNECTING 510.XXXS TO A RAIN SENSOR

510.xxxS is available with 2 additional wires for rain sensor connection:

1. Select a rain shut off device that is "normally open" or capable of being configured to be normally open (i.e. HUNTER MINI CLIK and RAIN BIRD RSD BEx.)
2. Carefully strip the controller's gray sensor wire back about six inches exposing the black and the red wires inside. Strip the tip of each wire back about 1/2".

- Connect the controller's black sensor wire to the "N.O." (normally open) wire from the sensor. Use waterproof wire connectors.
- Connect the controller's red sensor wire to the remaining wire from the sensor.
- Do not strip or cut wire if a sensor is not used.
- When sensor is active, $\frac{\text{H}}{\text{L}}$ appears on the display.
- Follow the sensor manufacturer's instructions for calibrating the sensor.

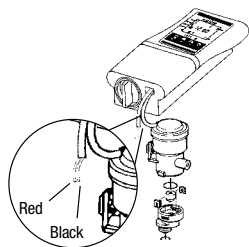

11. PROGRAMMING

This section explains the programming features, use of buttons and the steps necessary to assign irrigation schedules. To program the controller use the left button to select the desired programming mode, the right button to enter the mode and the plus minus buttons to change the value.

Note: Only a flashing character can be changed.

DIG controllers are programmed with the aid of four buttons:



Use to select the desired programming mode



Use to lower the value of the selected parameter (e.g. deducts an hour)



Use to raise the value of the selected parameter (e.g. adds an hour)



Use to select the parameter to be changed (hour, minute, etc.). To implement the changes, the selected parameter must be flashing.

If no changes are implemented, the controller will always revert to the main screen.

12. SETTING CURRENT TIME AND DAY OF THE WEEK

To enable the controller to operate properly, the current time and current day of the week must first be set. The steps below explain how to set the day and time.

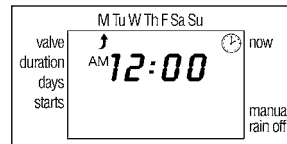

Press \leftarrow and the hour digit will flash. Use the \oplus or \ominus to set the current hour (note AM and PM designations). Press \leftarrow and the minute digit flashes. Set the current minute using \oplus or \ominus . Press \leftarrow and a flashing arrow will appear under "M" for "Monday". Use the \oplus or \ominus to move the arrow to current day. Press \rightarrow to proceed to the next step.

Note: If the last data entered stops flashing, press \leftarrow again to resume programming.

13. TIME FORMAT (SWITCHING BETWEEN AM/PM AND 24 HOUR)

The default time format is AM/PM. There is also a 24 hour time format option. It is a simple process to switch between the two formats.

Press \rightarrow several times until \odot appears.

Press \leftarrow and the hour digit will flash. Press the \oplus and \ominus simultaneously. The clock reading switches from AM /PM to a 24 hour time display or vice versa.

NOTE: The time display format can be switched at any step in the programming process.

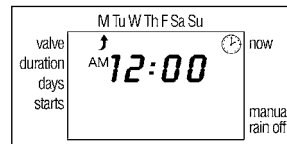

14. SETTING THE WATERING TIME (DURATION)

This setting determines the length of time that the valve will remain open.

Press \rightarrow until \odot appears. Press \leftarrow and the hour/minute digits flash. Set the desired number of hours by pressing \oplus or \ominus . Press \leftarrow again and the minute digits flash. Set the desired number of minutes by pressing \oplus or \ominus . Press \rightarrow to proceed to the next step.

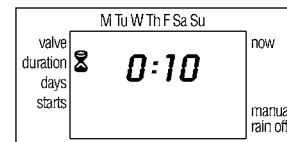

15. SELECTING WATERING FREQUENCY

This setting determines which days the controller will operate. Choose either “A) Watering According to the Days of the Week” or “B) One-time Irrigation or “C) Cyclical Irrigation”.

Press until appears. Press and a flashing arrow appears at the top of the display, under Monday. At this stage select one of 3 options:

- A) Watering according to the days of the week
- B) One time only watering or cyclical watering
- C) Cyclical Mode

A) WATERING ACCORDING TO THE DAYS OF THE WEEK

To select a watering according to the days of the week, move the flashing arrow to the desired day of the week by pressing . Press and the arrow under the selected day stops flashing. In a few seconds the arrow moves one position to the right, and flashes under the next day of the week.

Select additional days of the week in the same manner.

Press to proceed to the next step.

To cancel a scheduled watering day press and move the arrow under the selected day. Press under the selected day, the arrow will disappear and the flashing arrow will move one position to the right, and appear at the next day of the week. Cancel additional scheduled irrigation days in the same manner.

Press to proceed to the next step.

B) ONE-TIME IRRIGATION IN CYCLICAL MODE

This option is used to program the controller to operate the system one time only, for the irrigation period as set in watering time (durations).

Press until appears. Press several times (for all the days of the week) until appears, and **ONCE** flashes on the display.

NOTE: In cyclical mode only 1 start time per day is available.

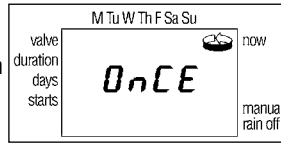
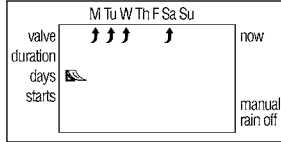

C) CYCLICAL MODE TO WATER EVERY X DAYS

Press until appears. Press several times (to advance all the days of the week) until appears, and **ONCE** flashes on the display.

With the display flashing, press or . The number of days between watering appears on the display.

For example, if “every 30 days” appears, watering will take place once every thirty days for the irrigation period as set in duration. To change the number of days press or .

Press to proceed to the next step.

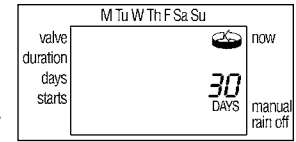

16. SETTING A START TIME – WATERING ACCORDING TO DAYS OF WEEK

In this step, up to 4 separate irrigation start times can be programmed in the weekly mode (watering according to the days of the week).

Press until START I appears. The word OFF (or the last start time entered) appears. Press the word OFF flashes. Press or to set the desired start time hour (note AM and PM). Press the minute will flash. Press or to set the desired start time minute. Press to set START II and repeat the same steps for start times number 2, 3 and 4 as needed.

To cancel one of the start times select it by pressing . Then press and the hour digit flashes. Press the or until the word OFF appears.

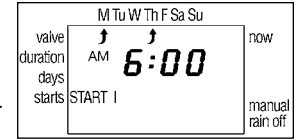

17. SETTING A START TIME – CYCLICAL OR ONE-TIME WATERING (WITH OPTION TO DELAY VALVE START TIME)

This program is used to pre-set the valve start time (only one start time available) and the number of days to delay the valve start time. The number of day(s) to delay option will appear on the display to the right of the irrigation start time above the word “days”.

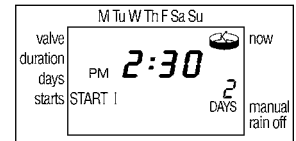

In this feature 0 days = program starts today; where 1 = program starts tomorrow, etc. (start can be delayed up to 30 days).

Press until START I appears or the last opening time entered appears on the display. Press and the hours and the AM/PM digits flash. Set the desired opening hour by pressing the or (note: AM and PM designations appear to the left of the hour digits). Press and the minute digits flash. Repeat the same steps for setting the minutes. To delay watering press again. The number above “days” flashes. Press or to change the number of days to delay the start time from today.

18. MANUAL OPERATION VIA THE CONTROLLER (SEMI-AUTOMATIC)

This option turns on the valve at any time and operates the system for the defined irrigation period. The valve will automatically close at the end of the irrigation period. The originally programmed irrigation schedule continues to function at the times set.

NOTE: In order to use semi-auto feature the controller must be programmed with the current day & time, duration, watering day & start time.

There are 2 ways to use the “semi-auto” feature.

Method 1: From the now screen () press and hold down the button for a few seconds. A water droplet icon and a appears in the display with the countdown of the remaining irrigation duration appearing a few seconds later. The valve will open and continue to water for the pre-programmed duration. If watering needs to be stopped before the full duration; simply press the button again.

Method 2: Press until appears. Press to open the valve. The word ON is displayed and a water droplet appears on the lower left side of the display. After 5 seconds, a count down of the remaining irrigation duration appears.

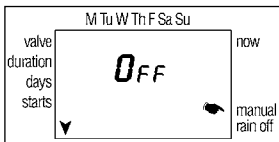
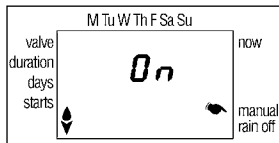

To close the valve manually before the end of the manual cycle press until ON appears again. Press to close the valve.

19. “RAIN OFF” (SHUTDOWN)

This option is used to temporarily suspend the controller operation. The irrigation schedule remains stored in the controller memory, but is not implemented until the suspension is canceled. The suspension option disables the valve.

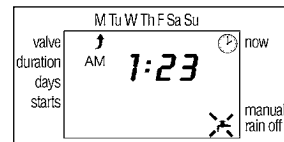

Press until appears. Press and hold down for 5 seconds until appears flashing. The controller is now suspended. To restore control to the controller, press until appears, and then press and hold down the until the disappears.

RAIN OFF can be used while a valve has been activated.

If an attempt is made to operate the valve manually while the controller has been suspended, or if the valve is programmed to open, the word “rain” appears, and the valve will not open.

20. BUDGET

Watering durations may need to be increased in hot weather and decreased in cool or wet weather. This can be done without affecting programmed schedules by specifying a percentage increase or decrease.

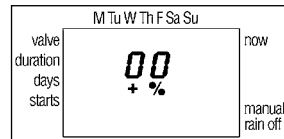

Press until appears, wait until no digit is flashing. Press simultaneously until 00+% is displayed. Press and the 00 flashes. Press or to increase or decrease the percentage as necessary (in 5% increments from -95% to +95%). Displayed on the “now ” screen is +% or -% when a budget choice is entered.

21. SENSOR OPERATION (S MODELS ONLY)

To connect a sensor to the 510.xxxS, see section 10. In the current time mode, the sensor icon  will appear when the sensor is tripped and “SOFF” will appear in the manual mode if a manual start is attempted.

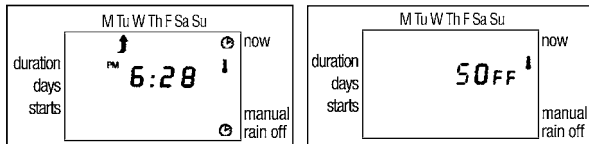

22. MISSING PROGRAM DATA

During “manual” operation via the irrigation controller “no Prog” appears on the display (under MANUAL OPERATION), indicating that no time duration has been set for the valve. In this case, automatic opening of the valve is disabled.

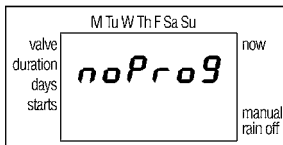

23. FLASHING LOW BATTERY WARNING

When the batteries are low, a flashing battery icon appears. In this state, the batteries still enable valve operation, but must be promptly replaced.

After replacing the batteries, press any button to resume controller operation.

Programmed data is retained if batteries are replaced within a 30 second time period

HINT: Simply replace one battery at a time.

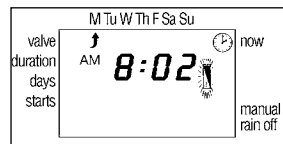

24. CONSTANT LOW BATTERY WARNING

When the batteries are low and not replaced in a timely manner, the battery icon is displayed. All other display elements disappear and all valves are closed. Replace batteries promptly, and press any button to resume controller operation. Programmed data is retained if batteries are replaced within a 30 second time period.

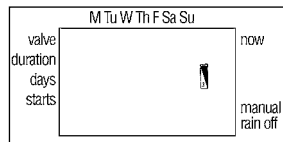

25. MAINTENANCE, TROUBLESHOOTING AND REPAIRS

- Batteries should be removed if the irrigation controller will not be operated for a prolonged period.
- Under normal usage, batteries (alkaline) will last for a minimum of 1 year, maximum of 2 years.
- It is good operating practice to replace old batteries with new ones at the start of the irrigation season.
- Recommended operating water pressure range: 7-80 PSI.
Operating pressure range 7-150 PSI.

PROBLEM

Valve does not open during automatic operation or during “manual” operation via irrigation controller

CAUSE: Manual Lever not in AUTO position

SOLUTION: Place Manual Lever in AUTO position

CAUSE: Weak batteries

SOLUTION: Replace batteries

PROBLEM

No display

CAUSE: Weak batteries

SOLUTION: Replace batteries

PROBLEM

Valve does not close despite clicks heard during activation

CAUSE: Manual Lever not in AUTO position

SOLUTION: Place Manual Lever in AUTO position

CAUSE: “O” Ring #2 is missing between the valve and the valve coupling

SOLUTION: Install a new “O” Ring #2

CAUSE: Outlet flow may be too low (minimum flow .5 GPM or 30 GPH)

SOLUTION: Increased flow rate by adding drip emitters or micro sprinkler

CAUSE: Valve is installed backwards

SOLUTION: Reverse valve

CAUSE: Solenoid orifice is blocked

SOLUTION: Flush and clear port

CAUSE: Poppet is missing

SOLUTION: Replace poppet

PROBLEM

Water leakage from the solenoid-valve coupling connection

CAUSE: “O” Ring #1 is missing (see Figure 1)

SOLUTION: Install a new “O” Ring #1

PROBLEM

Valve does not fully close

CAUSE: Debris stuck in diaphragm

SOLUTION: Remove bonnet and diaphragm and clean diaphragm

26. WARRANTY

DIG CORPORATION warrants these products to be free from defects in material and workmanship for a period of three years from date of purchase. This warranty does not cover damage resulting from accident, misuse, neglect, modification, improper installation or subjection to line pressure in excess of 150 lbs. Per square inch. This warranty shall extend only to the original purchaser of the product for use by the purchaser. This warranty shall not cover batteries or any malfunction of the product due to battery failure. The obligation of DIG CORPORATION under this warranty is limited to repairing or replacing at its factory this product which shall be returned to the factory within three years after the original purchase and which on examination is found to contain defects in material and workmanship. DIG CORPORATION SHALL IN NO EVENT BE LIABLE FOR ANY INCIDENTAL OR CONSEQUENTIAL DAMAGES OF ANY KIND; THE SOLE OBLIGATION OF DIG BEING LIMITED TO REPAIR OR REPLACEMENT OF DEFECTIVE PRODUCTS. SOME STATES DO NOT ALLOW THE EXCLUSION OR LIMITATION OF INCIDENTAL OR CONSEQUENTIAL DAMAGES, SO THE ABOVE LIMITATION OR EXCLUSION MAY NOT APPLY TO YOU.

Unattended use for prolonged periods without inspection to verify proper operation is beyond the intended use of this product, and any damage resulting from such use shall not be the responsibility of DIG CORPORATION. There are no warranties which extend beyond the description on the face hereof. In the case of purchase of the product for use other than, for irrigation purposes, DIG CORPORATION hereby disclaims any implied warranties including any warranties of merchantability and fitness for a particular purpose. In the case of the purchase of the product for personal, family or household purposes, DIG CORPORATION disclaims any such warranties to the extent permitted by law. To the extent that any such disclaimer or implied warranties shall be ineffectual, then any implied warranties shall be limited in duration to a period of three years from the date of the original purchase for use by the purchaser. Some states do not allow limitation on how long an implied warranty lasts, so the above limitation may not apply to you.

In order to obtain performance under this warranty, the unit must be returned to the factory, along with proof of purchase indicating original date of purchase, shipping prepaid, addressed as follows:

DIG CORPORATION, 1210 Activity Drive, Vista, CA 92081. Repaired or replaced units will be shipped prepaid to the name and address supplied with the unit returned under warranty. Allow four weeks for repairs and shipping time. Repair of damaged units not otherwise within warranty may be refused or done at a reasonable cost or charge at the option of DIG CORPORATION.

This warranty gives you specific legal rights, and you may also have other rights which vary from state to state.

TECHNICAL ASSISTANCE

Should you encounter any problem(s) with this product or if you do not understand its many features, please refer to this instruction manual first. If further assistance is required, DIG offers the following customer support:

TECHNICAL SERVICE USA

- **DIG's Technical Service Team** is available to answer questions from 8:00 AM to 5:00 PM (PST) Monday-Friday (except holidays) at 800-322-9146
- **Questions** can be e-mailed to questions@digcorp.com or faxed to 760-727-0282
- Specification documents and manuals are available for downloading at www.digcorp.com.



1210 Activity Drive
Vista, CA 92081-8510, USA

Website:

www.digcorp.com

e-mail: dig@digcorp.com

031309 DIG CORP 26-028

Printed in the USA

DIG is a Registered Service Mark of DIG Corp.

