



Series 1700 and 2630 Disc Filters

INSTRUCTION MANUAL

GENERAL INSTRUCTIONS

Series 17090 and 2630 disc filters utilize grooved plastic discs stacked together to form an effective filtering element under hydraulic pressure. They have been designed and manufactured to achieve the highest standards of quality and finish, and are used mainly as control filters for agriculture and municipal water supplies.

- Specially designed manifolds (series 9000), are available for mounting multiple filter arrays.

INSTALLATION

- Install the filter 3-5' above the ground
- Install Series 1700 vertically and Model 2630 horizontally
- Water inlet is clearly marked by arrow.
- Drain valve (8) should be at the bottom of the filter (Series 1700). Series 2600 optional.
- If more than one filter is installed, leave sufficient space between units to facilitate maintenance.

OPERATION

- Normal working conditions are obtained when headloss is less than 4 psi (0.25 bar) with clean filter discs.
- If headloss exceeds 4 psi (0.25 bar) – filter is either partially clogged or operating under an excessive flow rate.
- Maximal operational pressure should not exceed 120 psi (8 bar).
- Filter is designed to withstand a maximum pressure of 150 psi (10 bar).
- Verify headloss by inserting pressure gauge with needle into pressure testing ports, (7) assembled at inlet and outlet of filter.

WARNING:

Do not tighten or open cover during operation or under pressure.

- If pressure is not controlled effectively and might increase above 120 psi (8 bars), a pressure relief valve must be installed before the filter

PERIODIC CLEANING

- Recommended cleaning of filter and checking of discs: every two weeks or when headloss reaches 15 psi (1.0 bar), and on completion of irrigation.
- 1 Close valve at the inlet of the filter.
 - 2 Open drain valve (Series 1700), or cap (Model 2630) to release pressure.
 - 3 Open tightening bracket and remove cover (3) and remove the filter element.
 - 4 Unscrew the tightening nut (51) counter clockwise until loose, then rinse the discs thoroughly.
 - 5 Verify that filter discs are undamaged.
 - 6 Verify that the O-Ring is in position.

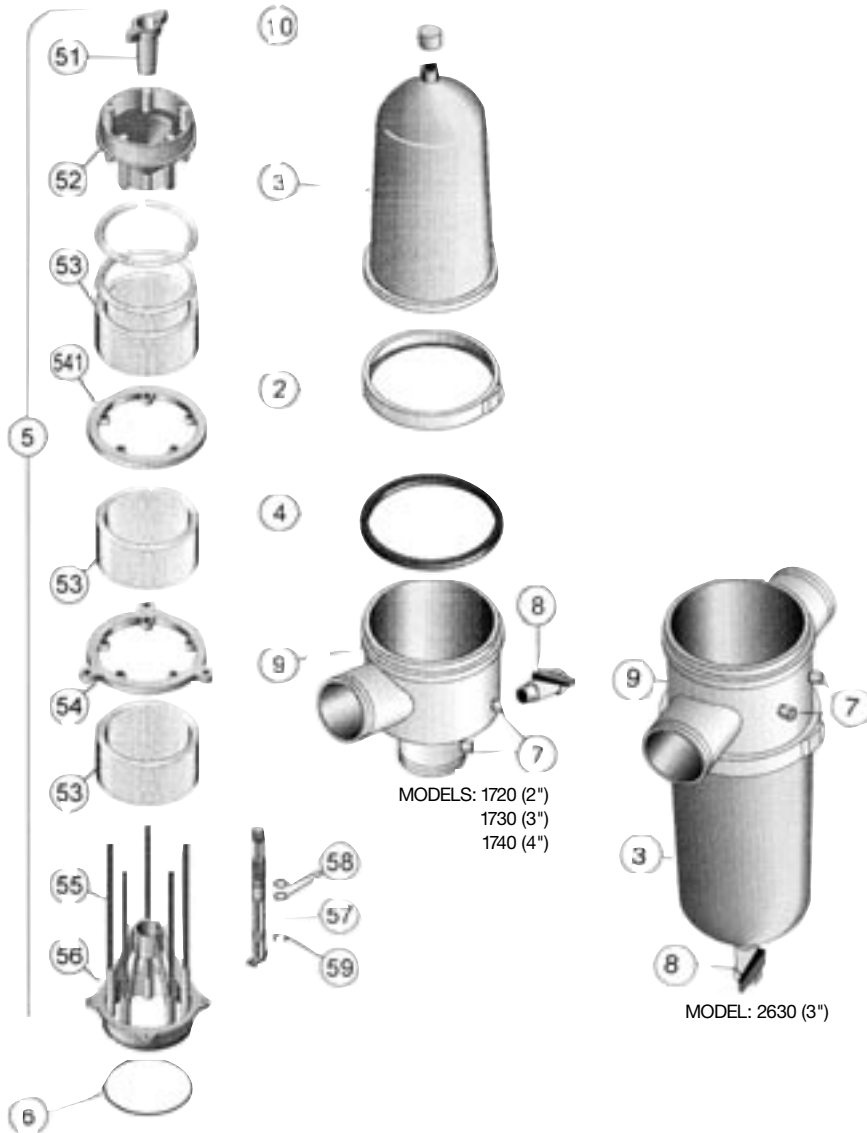

1290 Activity Drive, Vista, CA 92081-8510
760-727-0914 • 800-914-3326
Fax 760-727-0282
<http://www.digcorp.com>
e-mail: dig@digcorp.com



- 7 Manually close the tightening nut (51) clockwise until spine cover (52) reaches (without any pressure) the surface of the discs.
- 8 Replace filter element carefully into filter housing.
- 9 Place cover (3) on filter body.
- 10 Mount tightening bracket (2).
- 11 Check pressure reading again: headloss should be 4 psi (0.25 bar) or less.

NOTE:

- In case the rinsing does not remove particles from discs, immerse filter discs in acid/alkaline solution. Keep them there for some time then rinse thoroughly.
- Hydraulic pressure during filtering process causes fastening of the discs, and allows efficient filtering.
- Closing of the tightening nut (without pressure) leaves enough space between discs to allow good cleaning when automatic backflash is performed.

DIMENSIONS AND WEIGHT

Model	B		H		D		A		T		Weight	
	inch	mm	inch	mm	inch	mm	inch	mm	inch	mm	lbs	Kg
1720	2	50	20-1/2	520	8	200	6	150	4-1/2	115	27.5	12.5
1730	3	80	22	560	8	200	6	150	5-3/4	145	29.7	13.5
1740	4	100	25-1/4	640	8	200	6-1/4	160	8	200	38.5	17.5

Model	A		B		C		H		Weight	
	inch	mm	inch	mm	inch	mm	inch	mm	lbs	Kg
2630	12	305	3	80	6	150	31-1/4	790	26.4	12

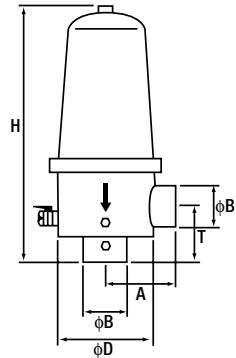
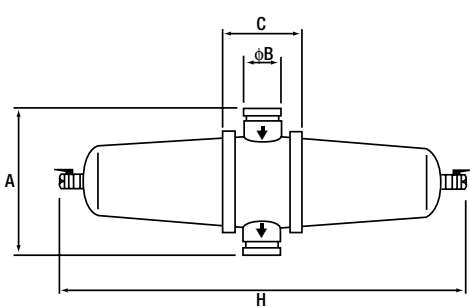

MAINTENANCE

- Any damage to the protective coating of filter must be repaired without delay. Prior to the application of the protective paint, thoroughly clean the damaged spot with wire brush.

PERFORMANCE

Model	Inlet & Outlet Diameters		Filtration Surface Area		Max Recommended Flow Rates	
	Inch	mm	sq. inch	cm ²	gpm	m ³ h
1720	2	50	249.5	1610	110	25
1730	3	80	249.5	1610	220	50
1740	4	100	325.5	2100	350	80
2630	3	80	341	2200	220	50

PARTS LIST / CATALOG NUMBERS

Part No.	Description	Model 1720 (2")	Model 1730 (3")	Model 1740 (4")	Model 2630 (3")
2	Tightening Bracket	58-263-002	58-263-002	58-263-002	58-263-002
3	Reinforced Plastic Cover	58-263-001	58-263-001	58-263-001	58-263-001
4	Cover Gasket	58-263-003	58-263-003	58-263-003	58-263-003
5	Disc Element	58-173-001	58-173-001	58-001-504	58-001-504
51	Tightening Nut	58-150-215	58-150-215	58-150-215	58-150-215
52	Spine Cover	58-150-210	58-150-210	58-150-210	58-150-210
53	Discs*	58-150-160	58-150-160	58-150-160	58-150-160
54	Spacer Ring	58-150-214	58-150-214	58-150-214	58-150-214
541	Round Spacer	58-263-014	58-263-014	58-263-014	58-263-014
55	Spine Rod	58-150-212	58-150-312	58-150-412	58-150-512
56	Spine Base	58-150-211	58-150-211	58-510-211	58-510-211
57	Center Bolt	58-150-213	58-150-213	58-150-213	58-150-213
58	Center Bolt "O" Ring	58-150-801	58-150-801	58-150-801	58-150-801
59	Center Bolt Clamp	58-150-216	58-150-216	58-150-216	58-150-216
6	Spine Base "O" Ring	58-150-802	58-150-802	58-150-802	58-150-802
7	Pressure Testing Port	58-000-800	58-000-800	58-000-800	58-000-800
8	Drain Valve	58-100-075	58-100-075	58-100-075	58-100-075
9	Filter Body	58-363-020	58-363-030	58-363-040	58-364-030
10	Cap 1"	58-110-101	58-110-101	58-110-101	58-110-101

* When ordering, please specify disc mesh

FILTERING GRADE

Disc Color	Mesh Grade	Micron	Disc Color	Mesh Grade	Micron
Brown	60	225	Red	120	125
Yellow	80	180	*Black	150	100

*For finer filtration at lower flow rates